

| BILL OF MATERIALS |        |     |
|-------------------|--------|-----|
|                   | PART # | QTY |
| 1                 |        |     |

| REVISION |             |      |
|----------|-------------|------|
| SYM      | DESCRIPTION | DATE |
| A        |             |      |

SECTION "A"

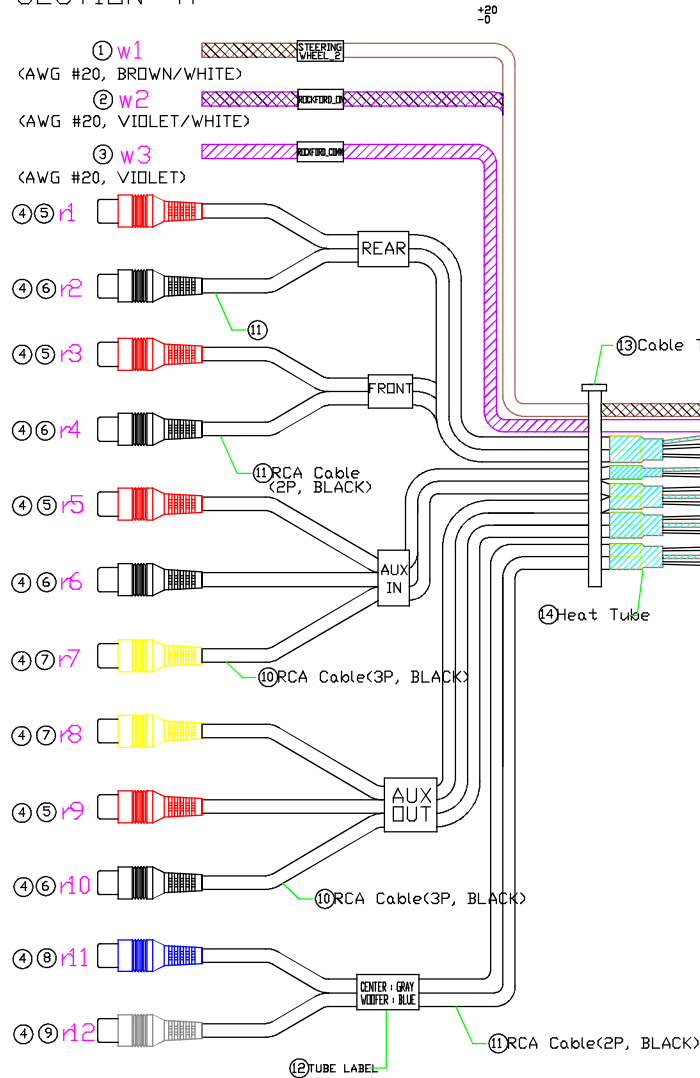

SECTION "B"

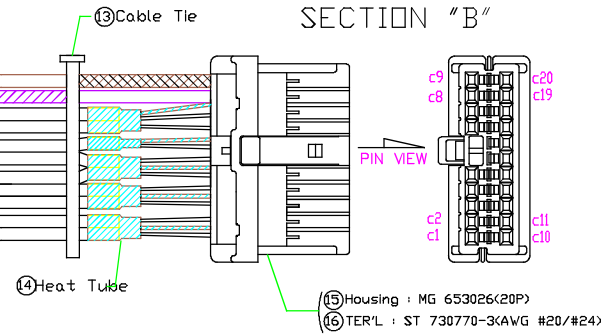

21953 PROTECTA DR.  
ELKHART, IN 46516

CUSTOMER:  
MODEL:  
BY: MIKE O'CONNELL  
DATE:

PART #